

EDON fiberglass

~ www.edon.com ~

FOR ANY SILICONE CLEAN-UP, EDON RECOMMENDS USING MINERAL SPIRITS

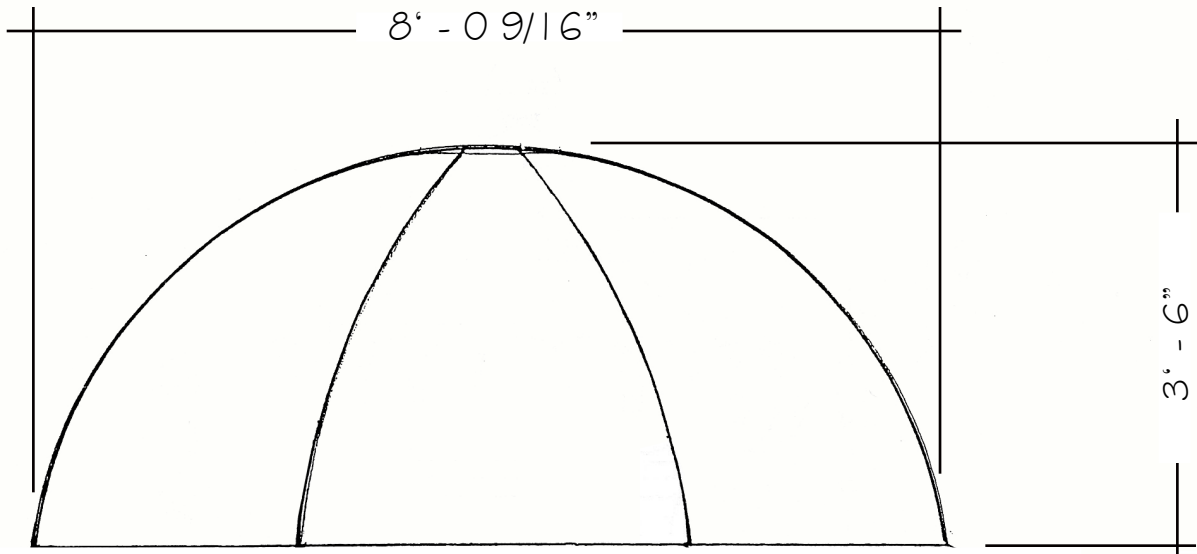

SECTION / ELEV. OF DOME

DOME SHIPPED IN 8 SECTIONS TO BE FIELD ASSEMBLED. ASSEMBLY SHOULD INCLUDE, FULLY CAULKING BOLT FLANGES WITH ADHESIVE/SEALANT

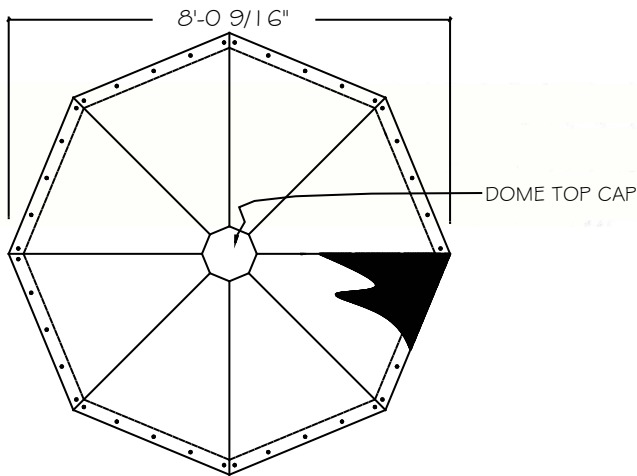

DOME PLAN DETAIL

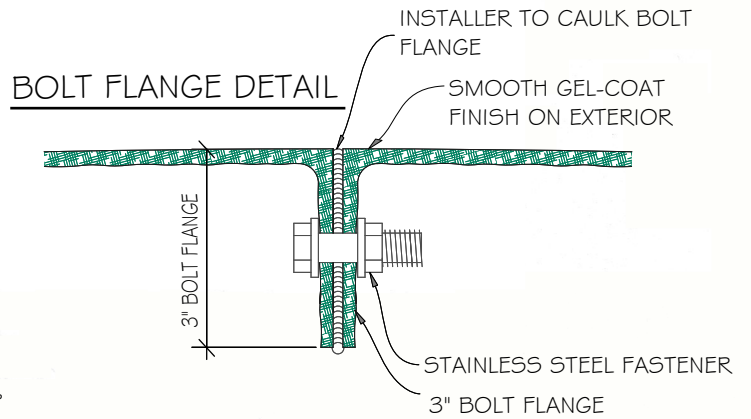

BOLT FLANGE DETAIL

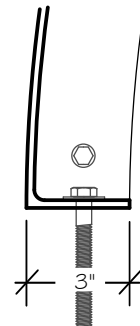

BASE BOLT FLANGE DETAIL

APPROXIMATE DOME WEIGHT = 280 LBS.

EDO-525 OCTAGONAL EXTERIOR DOME 8 SECTIONS

THIS SHEET IS FOR GRAPHIC REPRESENTATION AND REFERENCE ONLY.