

SECTION @ COLUMN CAPITAL

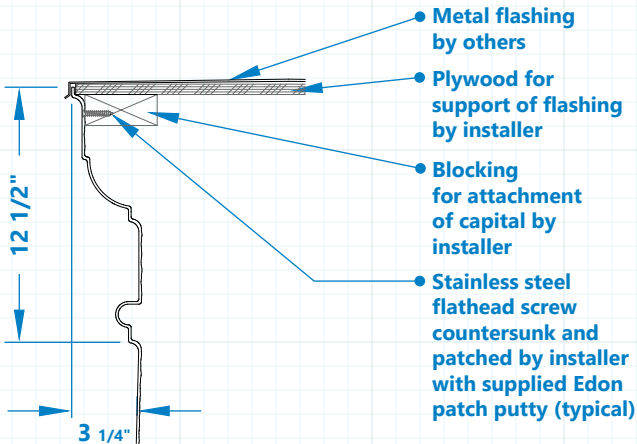

SECTION @ COLUMN BASE

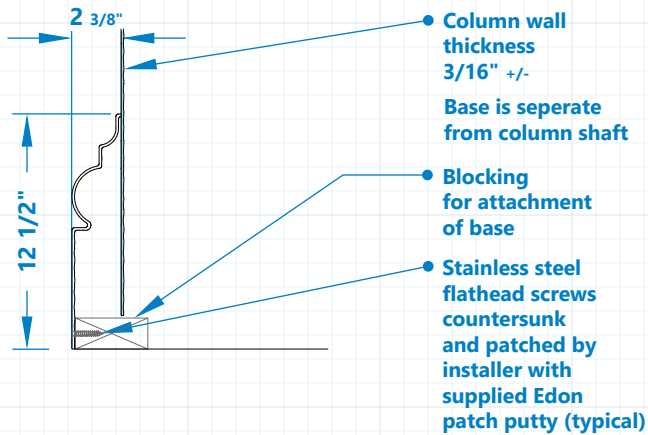

ELEVATION OF EC-120J COLUMN COVER

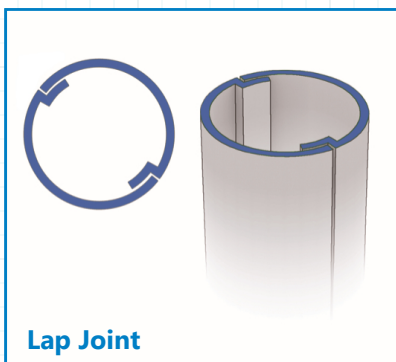
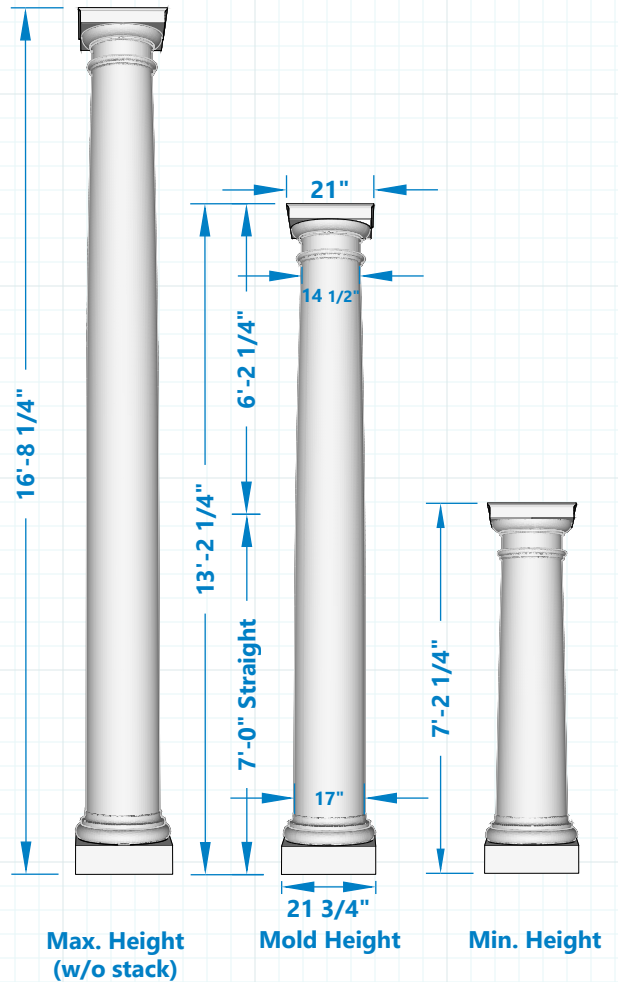

All fabricated in vertically split halves with a vertical lap joint, unless butt or reveal joints have been specified.

Capital is integrated with the shaft; Bases are separate pieces.

Column can be made to any height by stacking straight sections; illustrated maximum height is without sections.

EC-120J 17" Diameter | Tuscan Entasis Shaft Column Cover



EDON Composites
 (215) 672-8050 | info@edon.com | www.edon.com
 1160 Easton Rd. Horsham, PA 19044

